

FORKLIFT SAFETY

OSHA estimates each year approximately 100 workers are killed and 20,000 are injured in forklift accidents.

Forklift Inspection

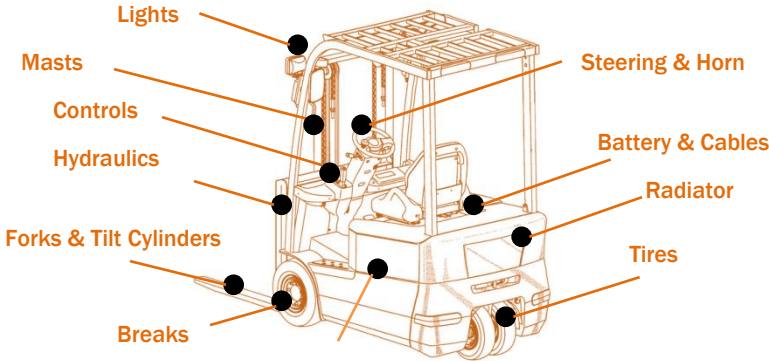

Forklift drivers must inspect the forklift daily prior to start of the shift.

Any defect or accident must be reported to the supervisor.

Unsafe vehicle must be locked out until the unsafe condition is corrected.

Forklift Operation

- Forklift driver must receive forklift operation training prior to operating a truck.
- Forklift must be inspected each shift.
- Don't allow riders on forks or platforms.
- Stunt driving and horseplay are prohibited.
- Don't trap anyone between the truck and another object.
- Don't move the forklift until the load is safe and secure.
- When lifting, lowering or carrying a load, tilt the mast slightly back to cradle the load.
- Keep arms, legs, head and feet inside the forklift when driving.
- Look in the direction of travel before moving a truck.
- When the load obstructs view, operate the truck with the load trailing.
- Slow down and use horn at cross aisles and locations where vision is obstructed.



REMINDER



When a forklift is traveling at 10 mph it takes about 22 feet for it to come to a full stop on a dry surface.

Check for Understanding

- Give examples of three forklift hazards in your work area.
- When should the forklift driver inspect the forklift vehicle?
- Who is authorized to drive a forklift?



SAFETY

HEALTH

ENVIRONMENT

FORKLIFT SAFETY

SafetyTalk

TRAINING ROSTER

Date	Shift / Crew	Trainer
No	Employee Name	Employee Signature
1		
2		
3		
4		
5		
6		
7		
8		
9		
10		
11		
12		
13		
14		
15		
16		
17		
18		
19		
20		
Follow-up / Recommendations / Corrective Actions		

SafetyTalk

OSHEPRO is a registered trademark of Southwest Consultants, LLC. This document cannot be used or reproduced without written consent from Southwest Consultants, LLC.

